

Light vehicle towing trailer regulations (GVM 4.5 tonnes or less)

Vehicle Standards Fact Sheet



MR25 8.14

There are a number of regulations that relate to how trailers are to be loaded and towed by a vehicle. They have been put in place to ensure that trailers are used effectively and safely, with minimised potential to harm individuals and other road users.

Towing Trailers with a Load

Before towing a trailer, please ensure that all safety measures and towing regulations have been met. The following information covers the key requirements relating to the towing of trailers. Detailed information is contained in the Road Traffic Act and Regulations, 1961.

Towing Mass Limits

The maximum mass that can be towed by a vehicle is dependent upon a number of criteria. The loaded mass of a trailer or caravan must not exceed:

1. The rated capacity of both the tow bar and tow coupling.
2. The towing mass specified by the vehicle manufacturer, or the GCM (Gross Combination Mass) specified on the vehicle's registration certificate.

NOTE: The manufacturer of the towing vehicle may specify two different towing limits or the towing vehicle, depending on whether the trailer is fitted with brakes or not.

No manufacturer's specifications?

If the motor vehicle manufacturer has not specified a maximum towing mass and a GCM is not specified on the vehicle's registration certificate, the rules below apply. These vary according to the trailer's braking system.

- For a trailer fitted with brakes directly operated by the driver, the mass of the trailer must not exceed 1.5 times the unloaded mass of the towing vehicle.
- For a trailer fitted with Over-Ride/Over-Run brakes not directly operated by the driver, the mass of the trailer must not exceed the unloaded mass of the towing vehicle.
- For a trailer not fitted with brakes the mass of the trailer must not exceed the unloaded mass of the towing vehicle or a GTM (Gross Trailer Mass) of 750 kg, whichever is the lesser.

Trailer braking regulations:

- Trailers must be fitted with brakes if the GTM exceeds 750 kg.
- Over-Ride/Over-Run brakes are acceptable up to a GTM of 2 tonnes.
- Where the GTM exceeds 2 tonnes the braking system must be fitted with a breakaway system that causes the brakes to be applied if the trailer becomes disconnected from the towing vehicle.

NOTE: These braking regulations apply within the towing mass limits detailed above.

Further information

Call 1300 882 248

Visit sa.gov.au

Email dpti.vehiclestandards@sa.gov.au



Government of South Australia

Department of Planning,
Transport and Infrastructure

Trailer Load Projections

There are limits to how far loads can project from the back and sides of a trailer.

Side Projection

A load must not project more than 150 mm over the sides of the trailer, and must not be more than 2.5 metres in total width.

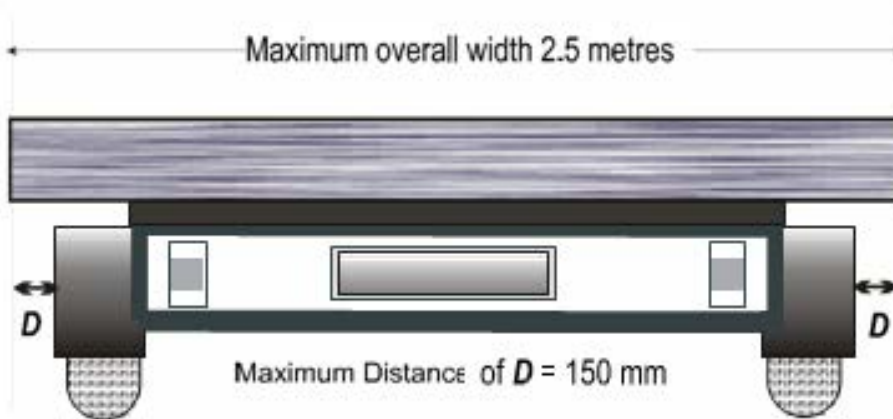

Length of Vehicle and Trailer

The overall length of the towing vehicle and trailer must not be more than 19 metres. Flag required if load is inconspicuous or rear projection is over 1.2 metres.

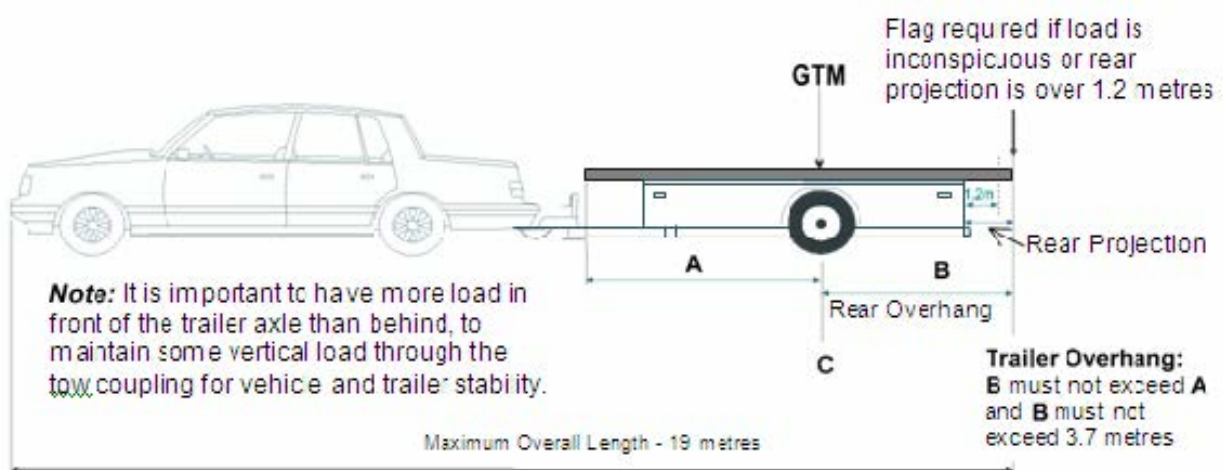

Further information

Call 1300 882 248

Visit sa.gov.au

Email dpti.vehiclestandards@sa.gov.au



Government of South Australia

Department of Planning,
Transport and Infrastructure

Rear Projection

Measured from the centre of the trailer axle, or axle group, a load must be:

- not more than 3.7 metres; and
- not longer than the length of the load in front of the axle, or axle group.

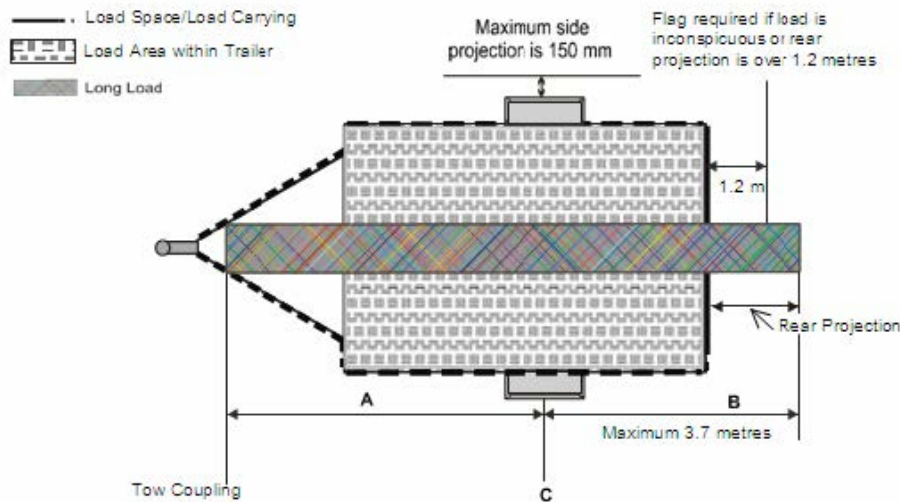

Trailer lighting and wiring

Lights on trailers must operate in unison with those of the towing vehicle. In other words the indicator, brake, tail and reversing lights, must go on when those of the towing vehicle go on.

Required Trailer Lighting, at the rear of trailer:

- Number plate light (may be combined with the tail lights)
- One pair of brake lights
- A pair of tail lights (may also be used to delineate the number plate)
- One pair of direction indicator lights that may also be used as hazard lights if necessary
- One pair of red reflectors.

If the trailer is more than 2.2 metres wide, reflectors must be fitted symmetrically to the front of the trailer and within 400 mm of the sides of the trailer. All trailers are required to have an earth wire connected through the wiring back to the towing vehicle. All wiring must be secured at least every 600mm.

Towing rules

- A trailer must be securely coupled to the vehicle towing it and must have a safety connection such as a chain or cable that will keep the trailer connected to the towing vehicle in the event of an accidental disconnection of the tow coupling.
- A trailer must not be towed:
 - with a person in or on the trailer
 - if the load is placed in a way that causes the vehicle to be unstable.
- The load on a trailer must be safely secured or restrained before moving onto a road.
- If an item falls from the trailer onto the road, it is the driver's responsibility to remove it from the road. Penalties apply if a load is not secured properly.
- A trailer must not be towed unless it meets all the mass, lighting, and braking requirements.

Further information

Call 1300 882 248

Visit sa.gov.au

Email dpti.vehiclestandards@sa.gov.au



Government of South Australia

Department of Planning,
Transport and Infrastructure

Definitions

Gross Vehicle Mass (GVM) - This is the maximum loaded mass of a motor vehicle.

Gross Combination Mass (GCM) - In relation to a motor vehicle (towing vehicle), this is the maximum loaded mass of the motor vehicle and of any vehicles or trailers being towed by that motor vehicle.

Aggregate Trailer Mass (ATM) - The total mass of the trailer when carrying the maximum load recommended by the manufacturer. This will include any mass imposed onto the towing vehicle.

Gross Trailer Mass (GTM) - This is the maximum loaded mass transmitted to the ground by the axle, or axles, of the trailer when coupled to a towing vehicle. Except for semi-trailers, the difference between the ATM and GTM is usually small.

A = Mass of load

Mass on Tyres (unloaded trailer)

Mass on Towing Vehicle

Aggregate Trailer Mass (ATM) = A+B+C
Gross Trailer Mass (GTM) = A+B

Trailers manufactured after 1988

Trailers manufactured after 1988 must be constructed in accordance with the requirement specified in 'Vehicle Standards Bulletin Number 1' (VSB1). This can be located at <http://www.infrastructure.gov.au>

This publication represents the views of the authors and not necessarily those of the Minister for Transport, Energy, Infrastructure, Administrative Services and Government Enterprises, and Road Safety or the Department of Transport and Infrastructure. No responsibility is accepted by the Minister for any errors or omissions contained within this publication. The information contained within the publication is for general information only. Readers should always seek independent, professional advice where appropriate, and no liability will be accepted for any loss or damage arising from reliance upon any information in this publication.

Towing Safety Checklist

Use the following checklist to ensure that you meet the safety requirements for towing a trailer:

- Ensure that all trailer lights (brake, tail and indicator) are all working. You may need someone to help you with this.
- Ensure that the trailer is securely coupled to the towing vehicle.
- Ensure that the trailer's safety connection is secured properly to the towing vehicle.
- Ensure that the trailer load is correctly balanced so that there is some mass bearing through the tow coupling.
- That the load is safely secured to the trailer and does not present any danger to other people or property if it projects past the body (even if it meets all the dimension and safety requirements).
- Ensure that the loaded trailer meets the braking requirements.
- Ensure that the vehicle combination and load does not exceed the length and projection limits.
- Ensure that the mass of the trailer and load does not exceed the towing capacity of the vehicle.
- Ensure that the loaded mass of the trailer does not exceed the tyre capacity and that the tyres are inflated to recommended pressures.

NOTE: Before taking action to alter a vehicle, you should first seek advice from the Department of Planning, Transport and Infrastructure and confirm what needs to be done to be sure you do not commit to an unnecessary expense.

Further information

Call 1300 882 248

Visit sa.gov.au

Email dpti.vehiclestandards@sa.gov.au



Government of South Australia

Department of Planning,
Transport and Infrastructure